

MCNP6®

Current Efforts in Code Modernization and Capability Development

Michael E. Rising
MCNP Technical Lead
XCP-3: Monte Carlo Group

August 2020



Managed by Triad National Security, LLC for the U.S. Department of Energy's NNSA

LA-UR-20-26456

MCNP Development Team

Team: XCP-3

Terry Adams

Jerawan Armstrong

Simon Bolding

Forrest Brown

Jeff Bull

Art Forster

Grady Hughes

Colin Josey

Joel Kulesza

Michael Rising

Sriram Swaminarayan (CCS-7)

Computer Support

Laura Casswell (WRS-SNA)

Data Team: XCP-5

Jeremy Conlin

Nathan Gibson

Wim Haeck

Kent Parsons

University R&D

William Martin

Brian Kiedrowski

Christopher Perfetti

Todd Palmer

This is an exciting time for Monte Carlo at LANL!

- Recent and ongoing investments in MCNP modernization are enabling new code developments using modern programming tools and languages
- New and challenging applications continue to drive new research and developments beyond the rich set of established MCNP capabilities
- The LANL MCNP radiation transport code has been the international gold standard for particle transport applications for over three decades.

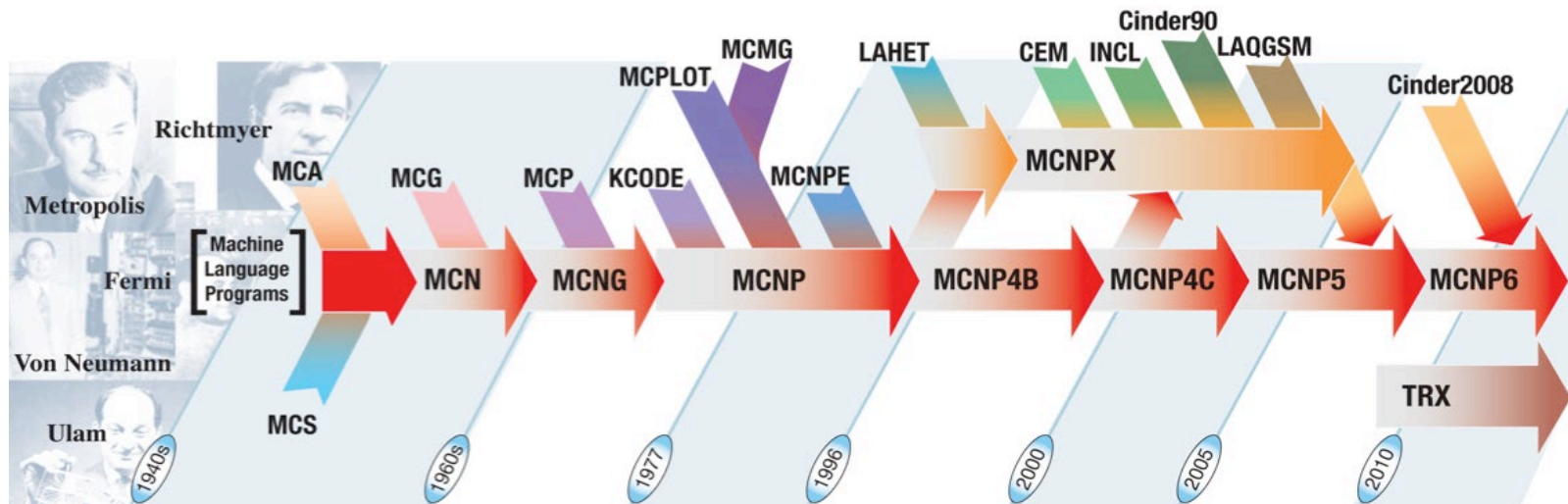

... when has it not been an exciting time for Monte Carlo at LANL?

LANL's Long History with Monte Carlo

- Monte Carlo Method for Radiation Transport Originated at LANL
 - Stanislaw Ulam, John von Neumann, Robert Richtmyer, and Nicholas Metropolis
 - Early calculations performed on the FERMIAC11 and MANIAC machines
- Monte Carlo code development and applications have been an important part of LANL efforts since that time

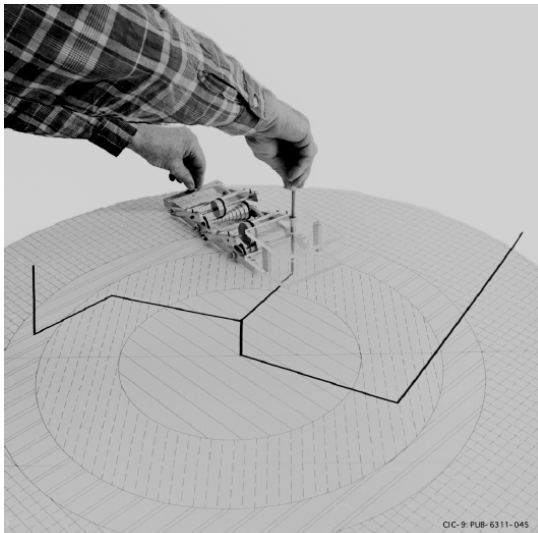

FERMIAC11 mechanically traced neutron paths



MANIAC computer performed early Monte Carlo calculations

The Vision of the Future Modernized MCNP is Modular

- Modernization via modularization
- Modular components
 - Improved testing → provable correctness of the code
 - Easier maintainability
 - Cleaner code
 - Component reuse
 - New features more efficiently developed and integrated
 - Early career staff excited to work on a more modern code



Significant Changes Are Guiding the Future of MCNP

- While the roots of MCNP go back a long time, there are many changes taking place now looking toward the future

- Adopting modern software development tools



Jenkins



- Converted to modern direct-access binary file formats, *HDF5*
 - Improved user workflow, e.g. better visualization tools
 - Faster development within a multi-physics framework

- Reorganization of source routines into modular components enabling future modernization work where needed

- C++ rewrite of several standalone capabilities

1940s

1977

2020

...

MCNP is a Trusted Capability Used in the Nuclear Criticality and Reactor Physics Communities

- For nuclear criticality, MCNP use is extensive and routine
 - World class V&V for criticality safety applications
 - For both static critical and subcritical systems at NCERC
 - MCNP is used extensively for criticality safety analysis throughout the DOE including PF-4 pit production applications
- For advanced reactor physics, MCNP use is growing
 - Very often used in code-to-code comparisons
 - Primarily used in static analysis

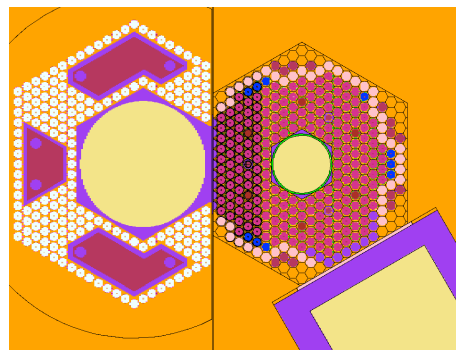

Sandia National Laboratory
ACRR Reactor

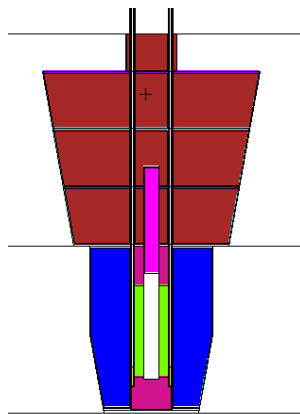

KRUSTY Experiment

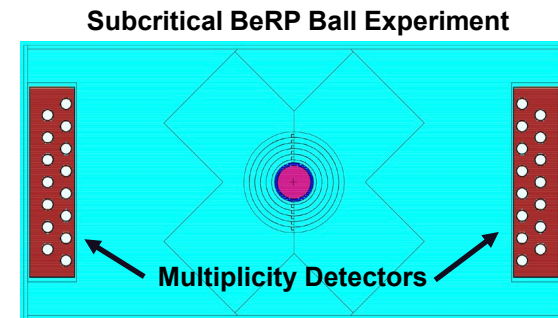
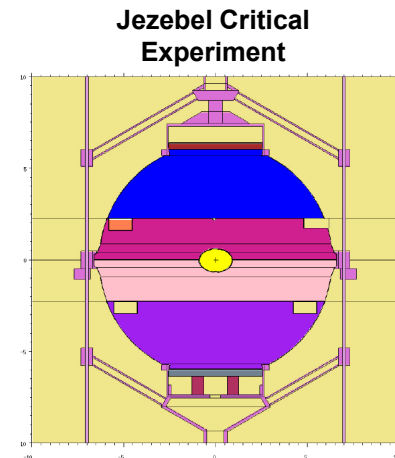

MCNP Unstructured Mesh Applications are Growing - Active Feature Developments and Opportunities

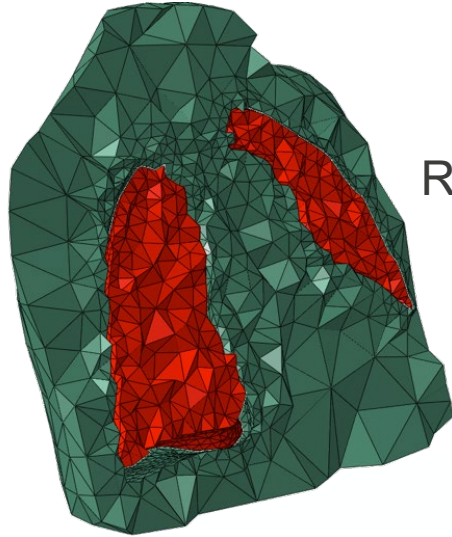

Medical Physics
Radiation Treatment
Planning

ITER Fusion Project
Neutron Flux
Calculations

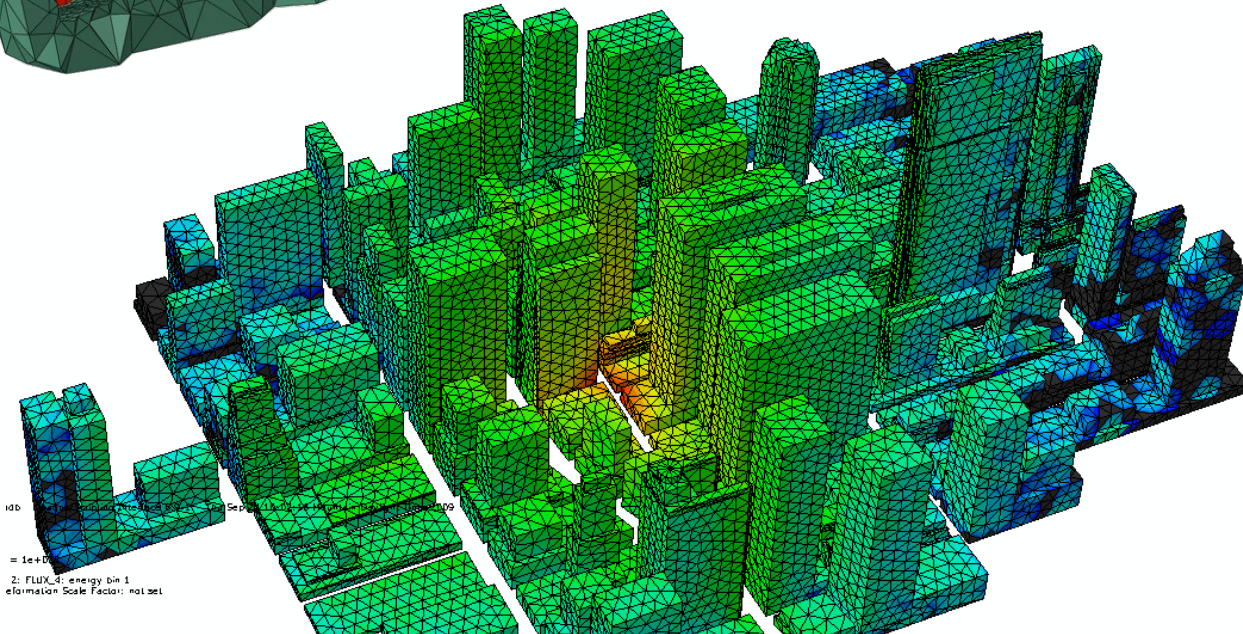
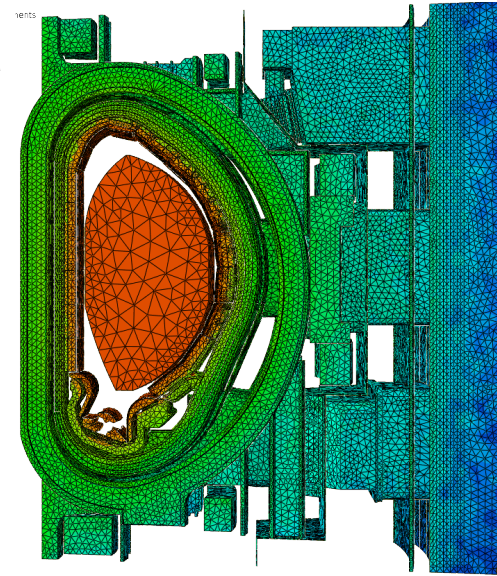

Gamma flux from
a "Fat Man-like"
explosion

Many LANL Core Missions and Global Applications Depend on the Capabilities MCNP Provides

- MCNP provides needed capabilities for many important LANL applications areas
 - Nuclear reactor physics
 - Nuclear critical / subcritical experiments (NCERC)
 - Criticality safety / operations (pit production)
 - Nuclear diagnostics, survivability
 - Nuclear weapon effects and outputs
 - Emergency response / nuclear threat assessments
 - Intrinsic radiation
 - Nuclear safeguards and nonproliferation
 - Radiation detection simulations (LANSCE)
 - Radiography (DARHT, pRad, NDSE, ECSE/Scorpius)

Unstructured mesh city model used to study nuclear weapon effects

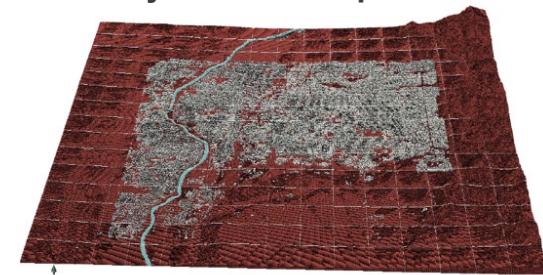

LANL's LANSCE cross section measurements enhanced by MCNP

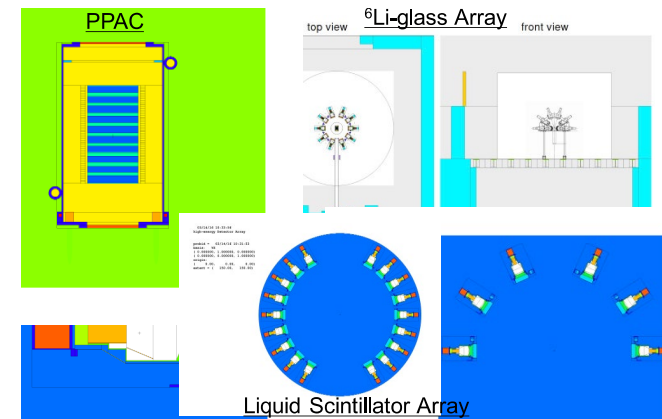

This is an exciting time for MCNP!

- MCNP code modernization is allowing us to develop new components of the code in modern programming languages using modern tools
- Exploration of multi-physics applications and how to efficiently and effectively connect to other physics packages is an exciting area of research that MCNP developers are actively involved in
- Recent and ongoing laboratory directed research and development projects have led to exciting new developments in the MCNP code
 - New unstructured mesh and multigroup cross section tally capabilities
 - New sensitivity/perturbation tally methods to be developed in connection with machine learning methods applied to nuclear data improvements and optimized experiment designs
- And many other research topics of interest... burnup/depletion, GPU parallelism, advanced visualization, correlated physics, etc.

Questions?

Michael E. Rising, mrising@lanl.gov

